

CTR-4011 - PARTS BREAKDOWN

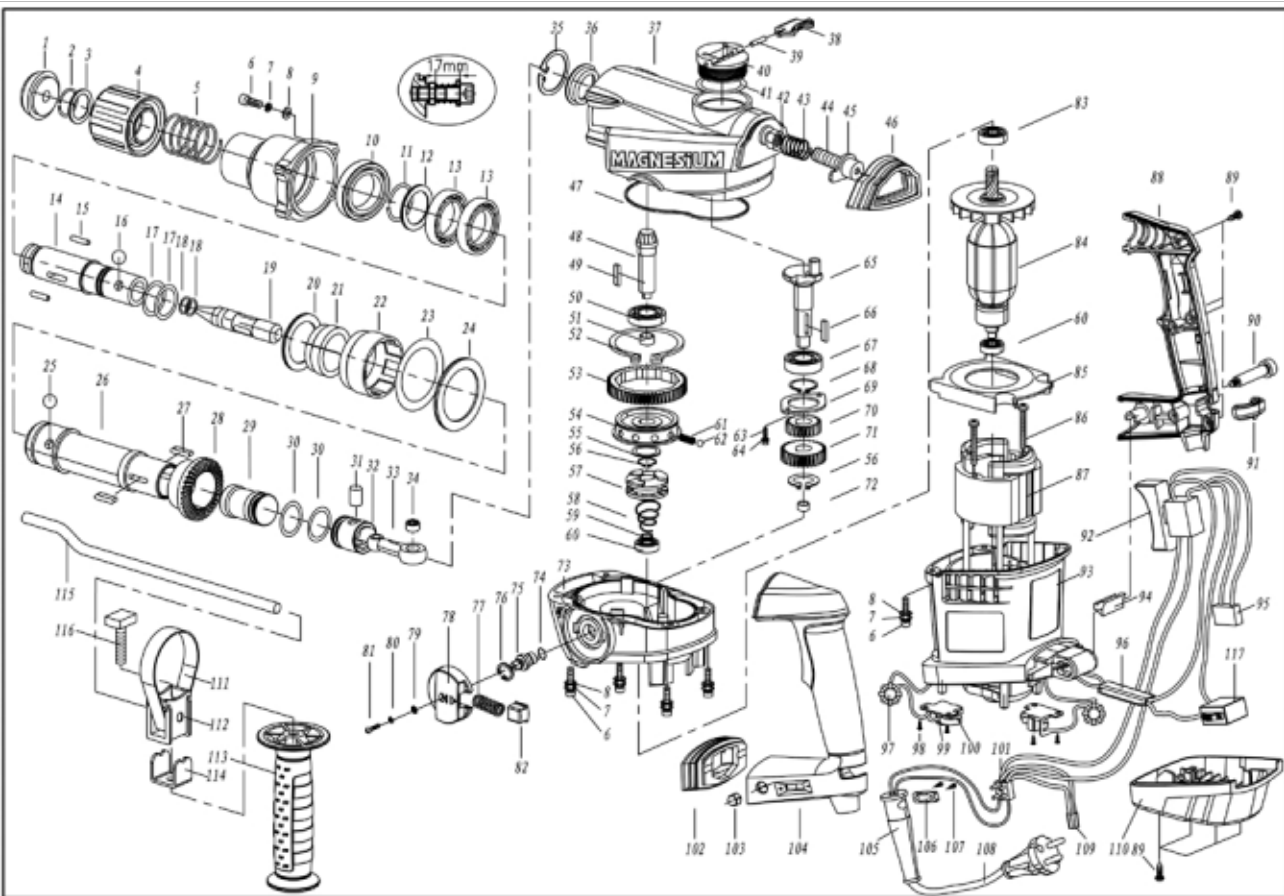

No.	Description	qty	No.	Description	qty	No.	Description	qty
1	Front cover	1	42	Hexagon nut M12	1	83	Bearing 6001	1
2	Circlip	1	43	Damping spring	1	84	Rotor	1
3	Washer	1	44	Hexagon nut M12x40	1	85	Air guider	1
4	Slider	1	45	Damping washer	1	86	Self tapping screw ST4.8X60	2
5	Spring	1	46	Up damping cover	1	87	stator	1
6	Screw M5X28	12	47	Seal ring	1	88	Right handle	1
7	Spring washer φ5	12	48	Small bever gear	1	89	Self tapping screw ST4.2X19	9
8	Flat washer φ5	12	49	Flat pin 4x22	1	90	Hexagon nut M6	1
9	Cylinder housing	1	50	Bearing 16003	1	91	Neon lamp cover	1
10	Grease Seal	1	51	Bearing HK152012	1	92	Trigger switch	1
11	Criclip	1	52	Circlip φ58	1	93	Motor plastic housing	1
12	Big washer	1	53	Flower hole gear	1	94	Damping block	1
13	Bearing 61808	2	54	Second gear	1	95	Capacitor	1
14	Guard sleeve	1	55	Washer	1	96	Wiring loom	1
15	Steel ball poleφ8x1	2	56	circlipφ15	1	97	Inductor	2
16	Steel ball φ7.94	3	57	Clutch	1	98	Self tapping screw ST4X12	4
17	O-ringφ28xφ2	2	58	Conical spring	1	99	Carbon brush set	2
18	O-ringφ19xφ2	2	59	Small washer	1	100	Brush holding set	2
19	Second striker	1	60	Bearing 608	2	101	Connecting terminal	1
20	Washer	1	61	Clutch spring	10	102	Down damping cover	1
21	Lock ring	1	62	Steel ball φ5.5	10	103	Domed cap nut M6	1
22	Plastic pipe	1	63	Spring washer φ4	2	104	Left handle	1
23	Seal ringφ68xφ59x2.5	1	64	Hexagon nut M4X13	2	105	Cable sheath	1
24	Big washerφ68xφ50x2	1	65	Crank shaft	1	106	Cable pressing plate	1
25	Steel ballφ9	3	66	Flat pin 4x16	1	107	Self tapping screw ST4X16	2
26	Cylinder	1	67	Bearing 6003	1	108	Cable	1
27	Flat key 3x18	2	68	Circlip φ17	1	109	Neon lamp	1
28	Big bevel gear	1	69	Bearing cover	1	110	Bottom cover	1
29	Striker	1	70	Small gear	1	111	Collar	1
30	O-ring φ28xφ3	2	71	First gear	1	112	Clamp holder	1
31	Piston pin	1	72	Needle bearing HK101610	1	113	Side handle	1
32	Piston	1	73	Gear housing	1	114	Locking block	1
33	Connecting rod	1	74	O-ringφ11xφ1.5	1	115	Stop rod	1
34	Needle bearing HK101612	1	75	Knob handle	1	116	Square head screw M8X45	1
35	Circlip for hole φ56	1	76	Circlip φ15	1	117	Speed controller	1
36	Oil bearing	1	77	Knob spring	1			
37	Crank housing		78	Side switch	1	119		
38	Moving plate	1	79	Small washerφ3	1			
39	Pin B4x40	1	80	Spring washerφ3	1			
40	Grease cover	1	81	Cross nut M3X12				
41	O-ring φ41xφ1.5	1	82	Locking block	1			